

Rev	Change note (from PDMW)	Changed	Date
01	First release	LHN	2018-01-31

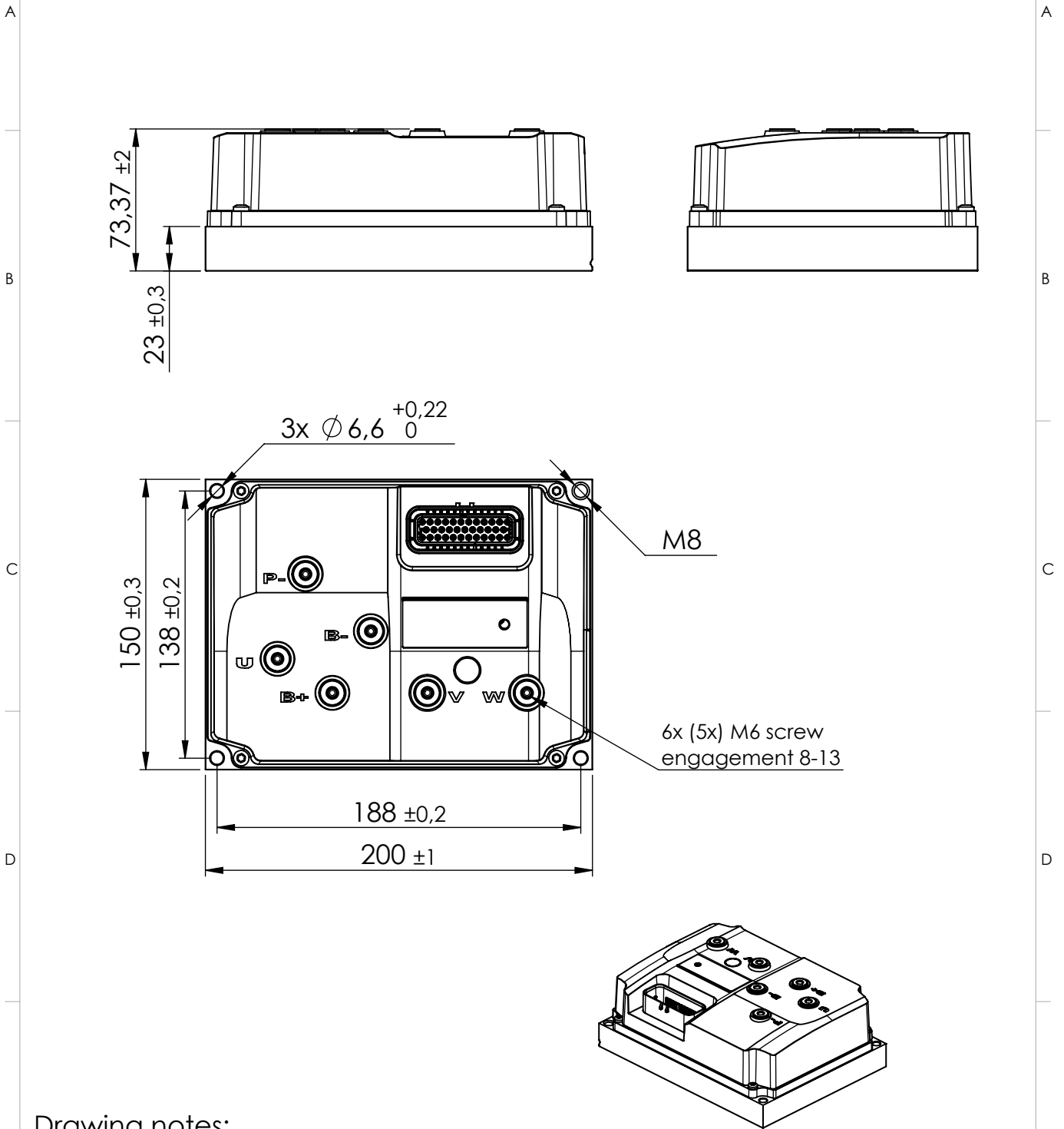

Drawing notes:

1. See 3D-model for further details.
2. Weight $\pm 10\%$
3. Pump (P-) connection is optional.

Material:

Surface Treatment:

Description

Standard ACS G7 S Heatsink C

Status released	Initial Designer LHN	Weight 2.3 kg	General Tolerance	General Roughness Ra:	Units mm
---------------------------	--------------------------------	-------------------------	-------------------	---------------------------------	--------------------

Document No. MC001872A		Rev 01	Page No. 1(1)	Projection View
----------------------------------	--	------------------	-------------------------	---------------------